

R-2000iA/T™ Series

Basic Description

FANUC Robotics' R-2000iA/T series of overhead, rail-mounted robots is the latest-generation, heavy payload member of the Toploader family of six-axis, modular construction, electric servo-driven robots designed for material handling and machine tending parts. The R-2000iA/T robots have the ability to perform value-added post-processing operations. They are engineered for precision, high-speed operation, user-friendly setup and maximum reliability, supported by our extensive service and parts network. The R-2000iA/T robots are ideal for heavy and very-heavy material handling challenges.

R-2000iA/T Series, the Solution for:

- Material handling
- Machine tool tending and post-process operations
- Injection mold machine unload and post-process operations
- Spot welding
- Die casting extraction
- Die spray dispensing
- Part transfer
- Palletizing

Benefits

- Combines the advantages of a linear gantry (large, scalable work envelope with limited floorspace requirements) and a FANUC six-axis articulated robot (dexterity, high reliability and maintainability).
- Services multiple vertical and/or horizontal machines.
- Adapts easily to existing plant layouts.



FANUC
Robotics

- Stationary outer arm simplifies hose and cable dressout, prolonging service life.
- Improves machine productivity by as much as 30 percent.
- Reduces capital and maintenance costs by allowing simple devices to replace complex material handling peripherals.
- Minimizes installation time and startup expense through easy installation alignment.
- Balances asynchronous processes by maintaining in-process part buffers.
- Performs value-added processing operations such as gauging, deburring, deflashing and labeling, in addition to basic material handling tasks.
- Based on proven, reliable standard FANUC Robotics product (R-2000iA).
- 125 kg (R-2000iA/125LT) and 200 kg (R-2000iA/200T) payload.
- Two orientations available to maximize either vertical extraction stroke (sideslung) or symmetrical work envelope (underslung).
- Rail speed of 2.5 m/s or 3 m/s.
- Rail travel lengths from 7 m to 48 m and longer.
- Family of standard support columns provide multiple robot height options. Supports on-site elevation adjustment.
- +/- 0.3 mm repeatability.
- Fail-safe brakes on all six axes.
- Brushless AC servo motors minimize motor maintenance.
- Robust rack and pinion rail drive.

Mechanical Features

- Modular rails can be attached to free-standing support legs with variable height attachment or to the fixed platen of an injection mold or die machine.

Options

- Severe Dust and Liquid Protection (SDLP) option for harsher industrial environments.
- Dual robot arms on a single rail.

R-2000iA/200T (Underslung)

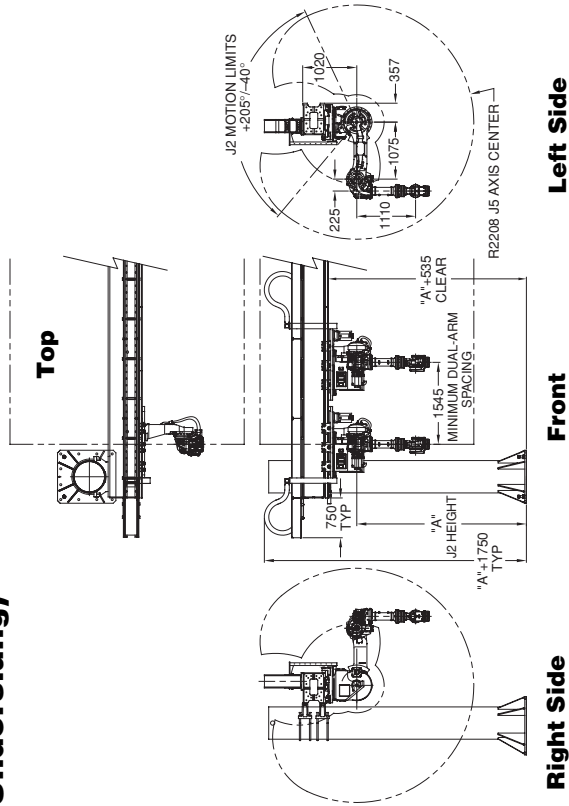

R-2000iA/125LT (Underslung)

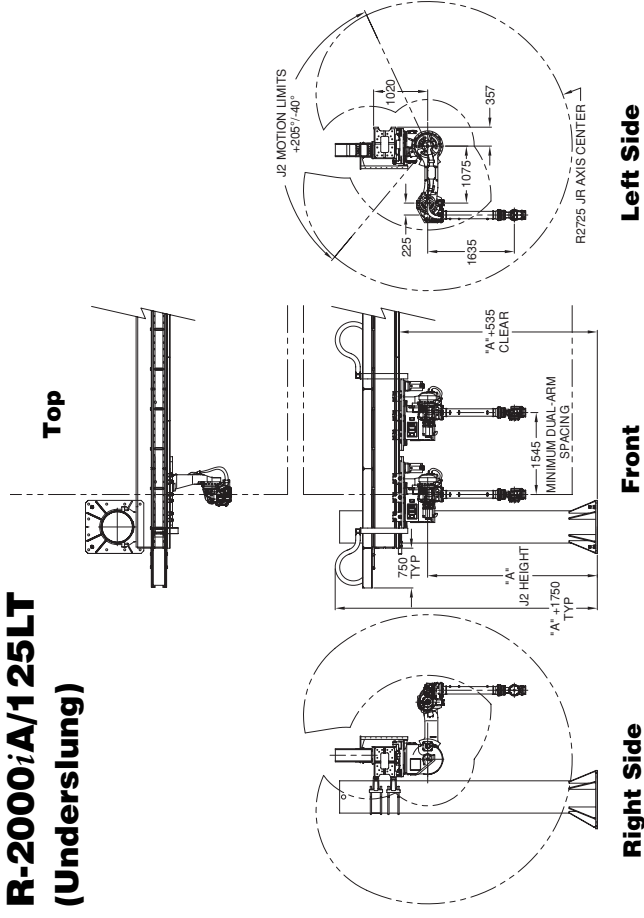

R-2000iA/200T (Sideslung)

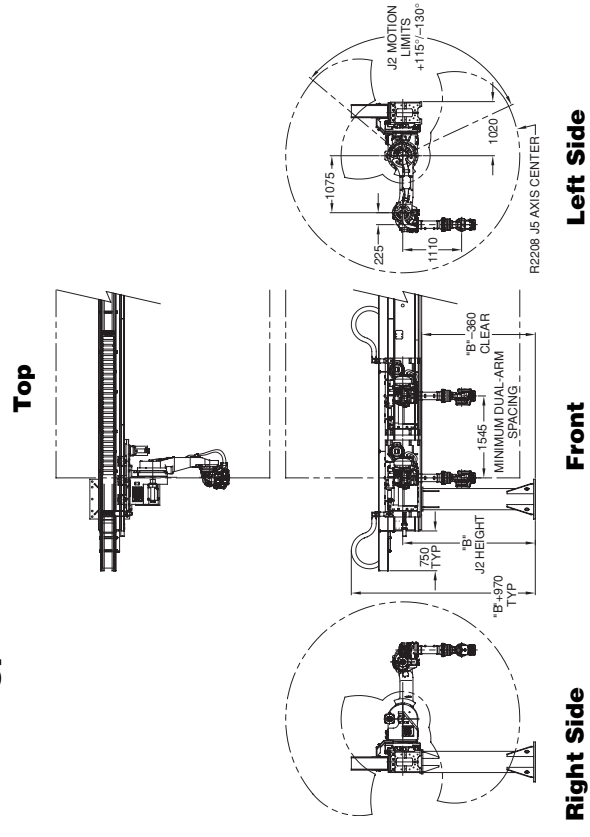

R-2000iA/125LT (Sideslung)

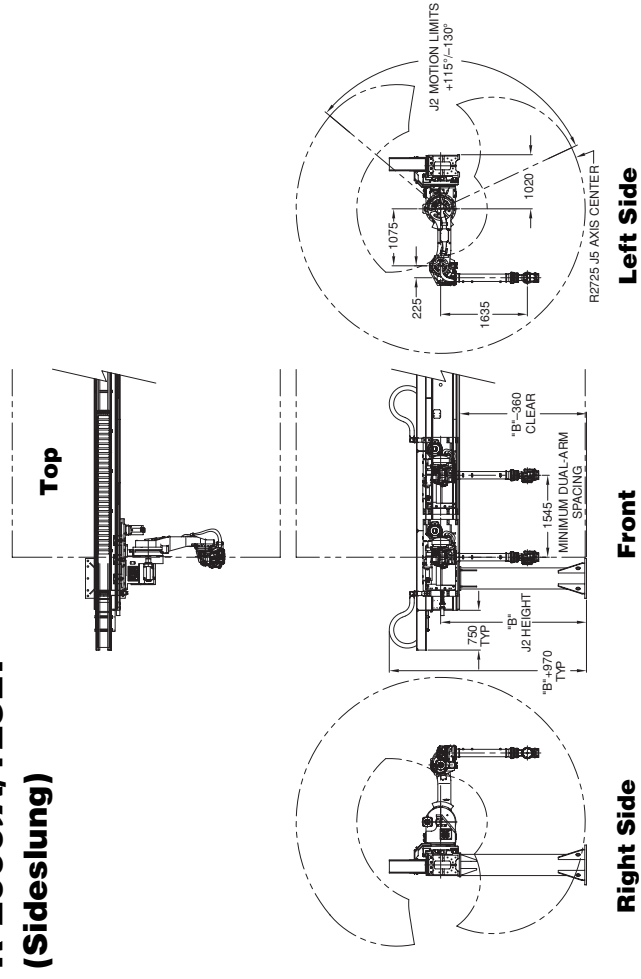

R-2000iA/T Series Rail and Column Guidelines

Underslung Footprint

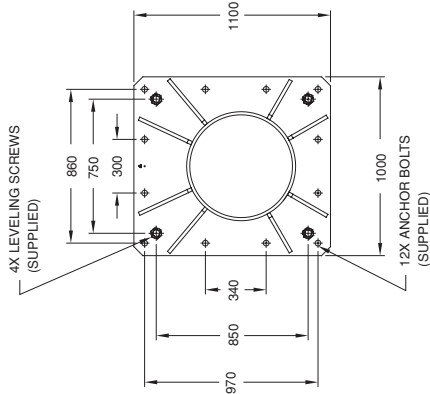

Sideslung Footprint

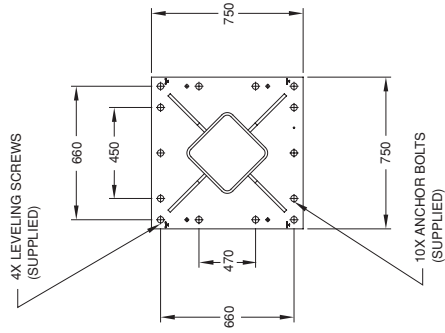

Single-section rails

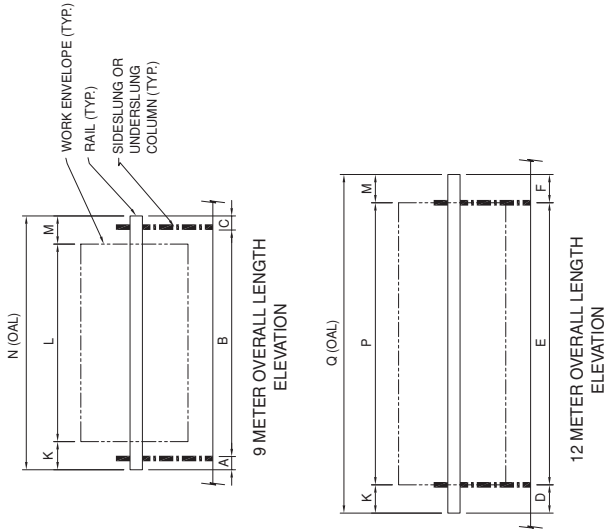

Multi-section rails

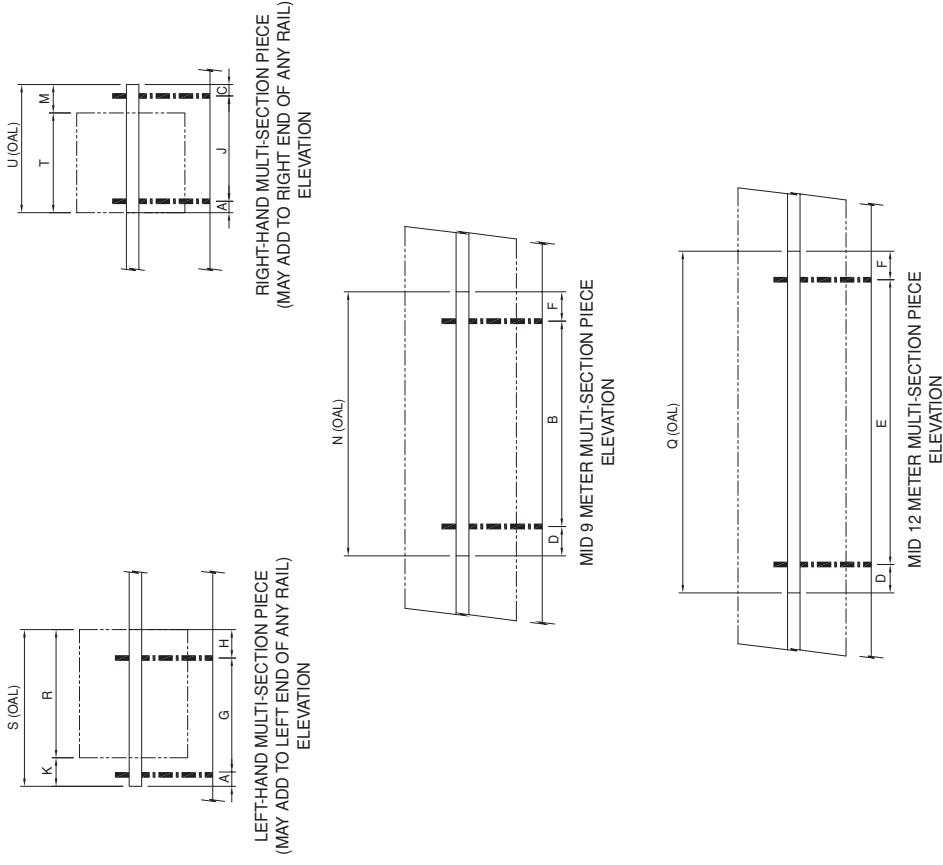

Tabulated Dimensions

COLUMN LOCATION DIMS	
STD	MIN. MAX
A	400 300 2500
B	8200 1000 8200
C	400 300 2500
D	1000 300 2500
E	10000 1000 10000
F	1000 1000 2500
G	4105 1000 10000
H	1000 1000 2500
J	3695 1000 10000

RAIL & ENVELOPE DIMS	
K	1000 mm
L	7000 mm
M	1000 mm
N	9000 mm
P	10000 mm
Q	12000 mm
R	4500 mm
S	5500 mm
T	3500 mm
U	4500 mm

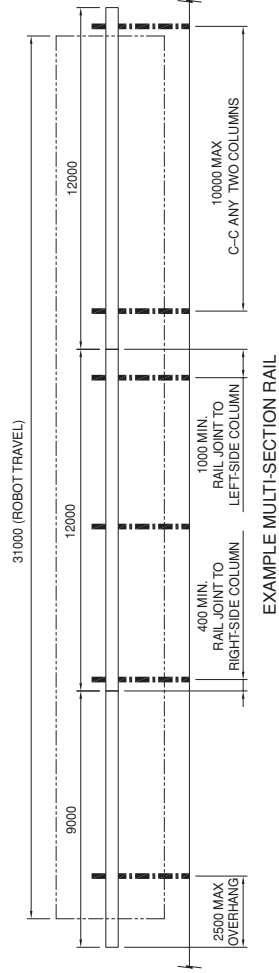

RAIL TRAVEL = SUM OF ALL OVERALL LENGTHS – 2000mm

R-2000iA/200T Specifications

Items		
Axes	6	
Payload - Wrist (kg)	200	
- J3 Arm (kg)	30 (J3 + Wrist ≤ 200)	
Reach (mm)	2207	
Repeatability (mm)	±0.3	
Interference radius (mm)	518	
Motion range (degrees)	J1	7 m - 50 m
	J2	245
	J3	406
	J4	720
	J5	250
	J6	720
Motion speed (degrees/s)	J1	2500 mm/sec. or 3000 mm/sec.
	J2	70
	J3	90
	J4	110
	J5	110
	J6	155
Wrist moment (kgf·m)	J4	130
	J5	130
	J6	70
Wrist inertia (kgf·cm·s ²)	J4	1200
	J5	1200
	J6	600
Mechanical brakes	All axes	
Mechanical weight (kg)	1080 (robot arm only)	
Mounting method	Sideslung or underslung	
Installation environment:		
Ambient temperature °C	0 to 45	
Humidity	Normally: 75% or less Short term (within a month): 95% or less No condensation (No dew or frost)	
Vibration (m/s ²)	4.9 or less (0.5G or less)	
IP Rating(s)	Wrist & J3 arm IP67, rest IP54, rail IPO	
Purpose	Overhead rail mount	

R-2000iA/125LT Specifications

Items		
Axes	6	
Payload - Wrist (kg)	125	
- J3 Arm (kg)	20 (J3 + Wrist ≤ 125)	
Reach (mm)	2725	
Repeatability (mm)	±0.3	
Interference radius (mm)	878	
Motion range (degrees)	J1	7 m - 50 m
	J2	245
	J3	352
	J4	720
	J5	250
	J6	720
Motion speed (degrees/s)	J1	2500 mm/sec. or 3000 mm/sec.
	J2	105
	J3	105
	J4	170
	J5	170
	J6	260
Wrist moment (kgf·m)	J4	60
	J5	60
	J6	35
Wrist inertia (kgf·cm·s ²)	J4	600
	J5	600
	J6	230
Mechanical brakes	All axes	
Mechanical weight (kg)	1080 (robot arm only)	
Mounting method	Sideslung or underslung	
Installation environment:		
Ambient temperature °C	0 to 45	
Humidity	Normally: 75% or less Short term (within a month): 95% or less No condensation (No dew or frost)	
Vibration (m/s ²)	4.9 or less (0.5G or less)	
IP Rating(s)	Wrist & J3 arm IP67, rest IP54, rail IPO	
Purpose	Overhead rail mount	

200T Wrist

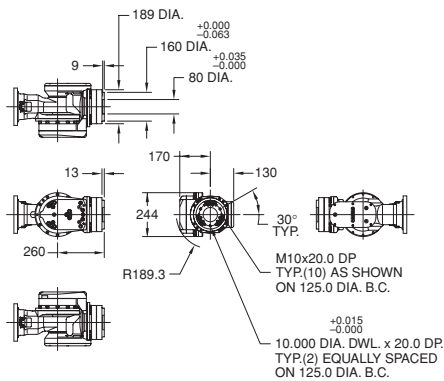

125LT Wrist

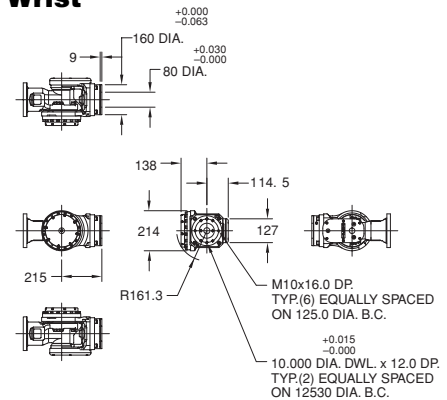

Note: Dimensions are shown in millimeters.
Detailed CAD data are available upon request.

FANUC
Robotics

FANUC Robotics America, Inc.
3900 W. Hamlin Road
Rochester Hills, MI 48309-3253
(248) 377-7000
Fax (248) 276-4133

Charlotte, NC
(704) 596-5121

Toronto, Canada
(905) 812-2300

Chicago, IL
(847) 898-6000

Montréal, Canada
(450) 492-9001

For sales or technical information, call:
1-800-47-ROBOT

Cincinnati, OH
(513) 754-2400

Aguaascalientes, Mexico
52 (449) 922-8000

Los Angeles, CA
(949) 595-2700

Sao Paulo, Brazil
(55) (11) 3619-0599

marketing@fanucrobotics.com
www.fanucrobotics.com

Toledo, OH
(419) 866-0788