

# P-50i

## Basic Description

FANUC Robotics' P-50i is a compact robot engineered to provide a precise, reliable, and affordable solution for coating a variety of consumer goods including appliances and automotive components. Its small size is ideal for companies with floor space constraints. The P-50i offers easy setup and maintenance, a large work envelope, and fast acceleration, resulting in minimized cycle times and lower production costs.

The design of the six-axis P-50i is based on the success of nine generations of coating robots. It has a modular construction, is electric servo-driven, able to operate in hazardous environments, and is supported by our extensive service and parts network.

## P-50i, the Solution for:

- General industrial coating
- Dispensing
- Lens coating
- Mask painting
- Space limitations

## Features and Benefits

- Floor, invert, and wall mounting permits versatility when unusual workpiece access is required.
- Patented, production proven, hollow wrist and through arm hose routing provide a clean application environment.
- Grease fittings on all lubrication points allow for quick and easy maintenance.
- Absolute serial encoders eliminate the need for calibration at power-up.
- Patented purge system for operation in hazardous environments.



- FM and CE Hazardous approval for Class I and II, Div. I, Group A, B,C,D,E,F,G environments.
- Flexible field hose allows fast installation.
- Lifting fixture for easy installation of wall or ceiling mount. (Option)
- Large envelope capable of working on both sides of the robot.
- Narrow base minimizes booth space and impact to airflow.
- Handles a variety of applicators including conventional and electrostatic air spray guns and rotary atomizers.
- Integrated micro valve color changer for short color change times and waste reduction. (Option)
- Able to use manifold-mount robot spray guns and rotary atomizers.
- WinOLPC is a user-friendly Windows-based, graphical programming interface for viewing, editing and teaching positions in Teach Pendant Programs. (Option)
- Extremely fast acceleration and deceleration motion results in faster cycle times.
- Line tracking and stationary applications.

## Process Advantages

- User-friendly Accuflow™ closed-loop fluid delivery system automatically maintains programmed flow rates, providing consistent material delivery and high finish quality. (Option)
- Collision Guard™ monitors for unexpected interference to reduce machine and applicator damage and maximize uptime.

## Reliability and Maintenance Benefits

- Standard RV drives
- Fully sealed drives
- Long lube cycle
- Designed for painting environment

**FANUC**  
Robotics

# P-50i Dimensions

## Isometric

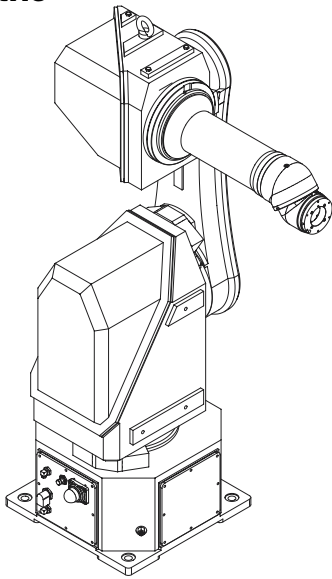

## Top

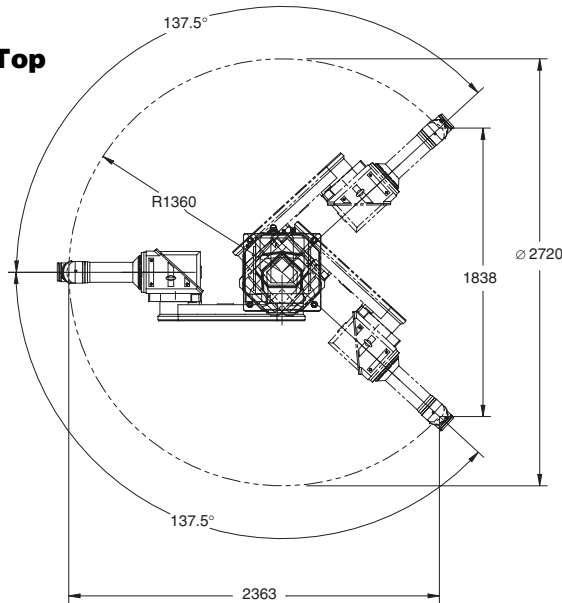

## Footprint

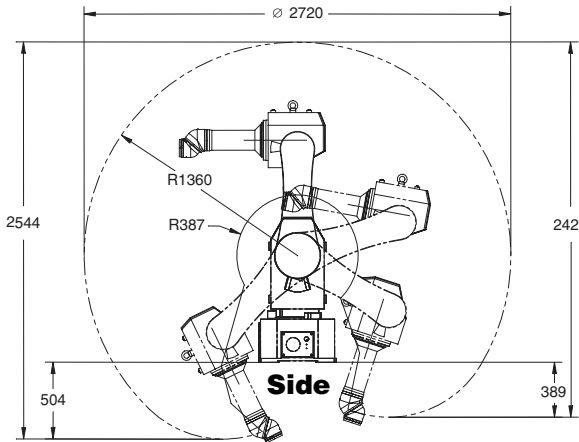
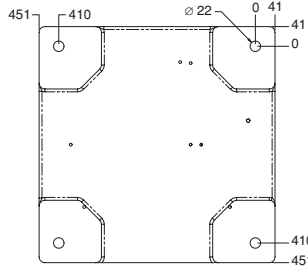

## Side

## Front

## P-50i Specifications

Items		
Configuration	6-axis vertically articulated	
Axes	6	
Payload - wrist (kg)	up to 7.5	
Outer Arm Payload <sup>(A)</sup> (kg)	up to 5	
Reach (mm)	1360	
Static Repeatability (mm)	±.2	
Motion range (degrees)	J1	±137.5
	J2	±135
	J3	±147
	J4	
	J5	±540
	J6	
Motion speed (degrees/sec.)	J1	160
	J2	160
	J3	160
	J4	460
	J5	480
	J6	600
Coating speed (mm/sec.)	1500	
Drive Type	Electric AC servo motor	
Position Encoders	Absolute pulse coders	
Mechanical brakes	Axes 2, 3, (1, 4, 5 & 6 optional)	
Mechanical weight (kg)	249 (robot arm only)	
Mounting method	Floor, Wall <sup>(B)</sup> , Invert	
Installation environment		
Ambient temperature °C	0 to 45	
Humidity	20-95% RH No condensation	
Vibration (m/s <sup>2</sup> )	Less than 0.5 G	
Certification	FM Class I, II, III/Div. I, Group A, B, C, D, E, F, G	

### Notes:

- (A) Mounted on top of elbow
- (B) Wall mount requires brakes on axis 1

## Wrist

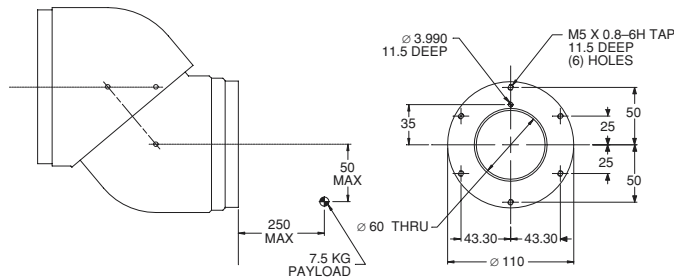

Note: Dimensions shown in millimeters.



**FANUC Robotics America, Inc.**  
**3900 W. Hamlin Road**  
**Rochester Hills, MI 48309-3253**  
**(248) 377-7000**  
**Fax (248) 276-4133**

Charlotte, NC  
 (704) 596-5121

Toronto, Canada  
 (905) 812-2300

Chicago, IL  
 (847) 898-6000

Montréal, Canada  
 (450) 492-9001

For sales or technical information, call:  
**1-800-47-ROBOT**

Cincinnati, OH  
 (513) 754-2400

Aguascalientes, Mexico  
 52 (449) 910-8000

Los Angeles, CA  
 (949) 595-2700

Sao Paulo, Brazil  
 (55) (11) 3619-0599

[marketing@fanucrobotics.com](mailto:marketing@fanucrobotics.com)  
[www.fanucrobotics.com](http://www.fanucrobotics.com)

Toledo, OH  
 (419) 866-0788